



The smallest weigh scale blender in the world

Ideal for small injection machines for up to 100 lb/hr (45 kg/hr).

Removeable hoppers

The WSB MB consists of 4 removeable hoppers, fitted with materials dispense valves for metering all materials.

Quick color changes

With no bolts or tools required, the removeable hoppers are ideal for quick color or additive changes, reducing downtime.

Dispense valve options

Our corner valve, pivot valve and carousel valve options are designed for poor flowing, free flowing and very small percentage settings respectively, to keep all materials flowing.

Up to 4 components

The standard MicroBlender is equipped with 1 Corner Valve for Re grind and 3 Pivot Valves for Natural, color and additive. There are 5 models available, which can achieve up to 100 lb/hr (45 kg/hr).

Batch size

The hoppers are mounted above the weigh bin with a default 0.88 lb (400g) batch size.

High consistent accuracy

On every material within $\pm 0.1\%$ on a 1% setting.

Sequential dispensing

The system tares the weight of the weigh bin and then each material is dispensed – Re grind, Natural, Color and Additive – in sequence to ensure accurate dispenses of every material within the blend.

Homogenous mix

A complete batch is released into the mixing chamber and mixed with the previous batch to ensure a homogenous mix.

Control of the mix

Material blending is controlled by a level sensor mounted in the upper part of the mix chamber to retain accurate mixing. When the sensor is covered, the blender will not dispense any further batches.

Easy set up

Settings are made easily by either user friendly thumbwheels or entering settings directly on the keypad / optional touchscreen.

Password protection

Special functions can be easily accessed and set via the password protect key.



Audible and visual alarms

An audible and visual alarm sounds should a batch be incomplete.

Reporting

Setup and operation reports can be printed direct to a USB key. Alternatively, data is also available via Ethernet or serial ports allowing remote access and monitoring.

Integration

Integration to other control or ERP systems can be made via leading fieldbus or OPC interfaces.

Quick cleanout

A compressed air gun is provided for quick cleanout.

Rapid color change

Easy access to all material contact surfaces of the machine including hoppers, weigh bin and mixing chamber allows for rapid color changes without the use of tools.

Controller

The Maguire controller monitors and confirms the weight of each ingredient and comes with an optional touchscreen.



WSB MB Gravimetric MicroBlender™ Dimensions

Compartments - 0.3 cu ft [8 Litres]

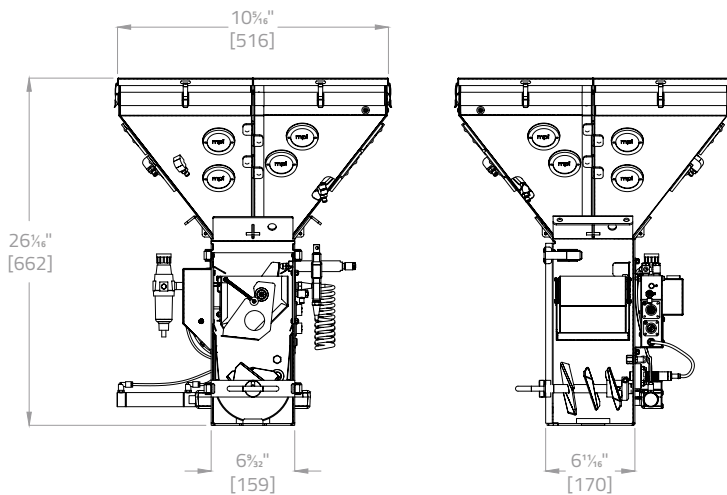

Footprint

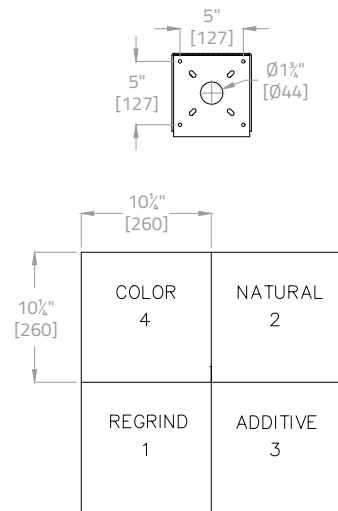

Technical data

Model WSB MB	
Maximum Throughput*	40kg/h to 60kg/h 100lb/h to 125lb/h
Number of Materials	4
Material Dispense Systems	1 Corner Valve 3 1.25" Pivot Valves
Weight	45Kg 100lb
Power Supply	110vac - 0.5 Amp 230vac - 0.2 Amp
Operating Air Pressure	3 Bar 40psi
Air Consumption	0.3 m ³ /hr 0.17cfm
Shipping Weight	50Kg 110lb
H x W x D	65 x 76 x 55cm 28.5 x 30.5 x 22in

*Throughput achieved is influenced by number of materials, how well they flow, vibration and loading consistency - each can effect maximum output of a blender, which in turn effects sizing the correct blender required for an application.

Key features

- Ideal for small processing machines
- Additional standby materials hopper
- Reduced weight and footprint
- Overall precision of ±0.1% of specified blend
- Compressed air gun for quick cleanout included
- Easy access to all material contact surfaces of the machine including hoppers, weigh bin, and mixing chamber permits rapid colour change without the use of tools
- Proprietary microprocessor-control technology monitors and confirms the weight of each ingredient / touch-screen optional.
- Compensation is made when a variation in dispense weight is detected
- Vibration Weighing management
- Improved documentation capabilities
- 5 Year Warranty



Maguire reserves the right to cancel product or change product, product specifications and data without notice to improve reliability, function, design or otherwise.

MAGUIRE WORLDWIDE DISTRIBUTION LOCATIONS



Maguire USA

Aston, PA, USA
T: +1 610 459 4300
F: +1 610 459 2700
E: info@maguire.com

Maguire Canada

Ontario, Canada
T: +1 905 879 1100
F: +1 905 879 1101
E: info@maguirecanada.com

Maguire Europe

Staffordshire, UK
T: +44 1827 338 280
F: +44 1827 338 285
E: info@maguire-europe.com

Maguire IMEA

Dubai, UAE
T: +971 4 881 6700
E: info@maguire-imea.com

Maguire Asia

Singapore
T: +65 6848 7117
F: +65 6542 8577
E: magasia@maguire-products.com.sg

Maguire China

Shanghai
T: +86 21 5882 3410
F: +86 21 5882 3420
E: amber@maguirechina.com