

# Low Profile Vacuum Loading System For Single And Multiple Blenders & Dryers

**Self-controlling, extremely compact receiver at up to 80% lower than traditional receivers.**

## Low Profile Design

At up to 80% lower than traditional receivers, the Maguire LowPro unit easily fits into your existing production set up. The low profile receivers provide a low centre of gravity that minimizes effects of vibration from fast-cycling processing machines.

## Autonomous Control

The system consists of autonomously controlled receivers which poll for vacuum, taking vacuum and loading when free. No separate control or complicated set up and settings – the system controls itself.

## Simple Connection And Installation

The cabling is plug and play with each component linked in sequence. Receivers load on a first-in / first-out basis.

## Brushless Motor

Vacuum is supplied from a mini-central unit on a portable stand and is powered by a single-phase brushless motor which requires minimal maintenance.

## Simple To Operate

Precise fill times can be applied using the user-friendly set time button.

## Alarms

Audible and visual alarms will notify the user if material is not loading on each receiver or the air filter needs attention.

## Large Discharge Flap

The wide discharge flap in the LowPro receiver is up to 4 times wider than the flap on a conventional upright receiver, making possible a dump time of under 2 seconds per cycle. This makes the system ideal for poor-flowing, low-density flake.

## Simplified Maintenance

All operating components are housed in a removable module that allows for quick, on-the-fly cleaning and maintenance and easy access to the filter.

## Automatic Filter Cleaning

Our patented "air blast" design, clears the entire filter area so effectively that the filter never needs to be serviced for routine cleaning.

## Check Valve

The check valve is being pulled up against the receiving line when not loading to control & maintain material flow.

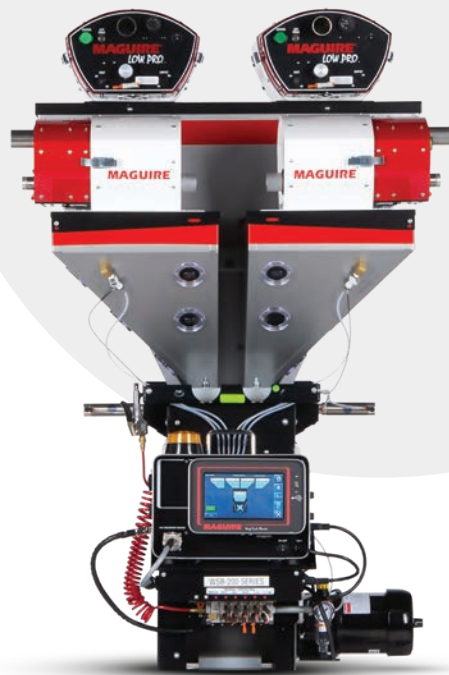

**80% REDUCTION IN HEIGHT**



## 5 Year Warranty

The LowPro system is supported by the Maguire 5 year warranty program.

## User-Friendly Side Access

With the unit positioned on its side, it's positioned at a height at which it's easy to access the vacuum pipe, filter, solenoid, alarm and electric connection; compared to multiple points of contact on conventional receivers.



## LowPro Specifications

Model	Capacity		Volume		Height		Standard Inlet Diameter	
	lb	kg	cu.ft	l	in	mm	in	mm
LPR-A4	5.5	2.5	0.14	4	7 5/8	203	1 1/2	38
LPR-A7	10.2	4.6	0.27	7.6	7 5/8	203	1 1/2	38
LPR-A12	18	8.2	0.45	12.7	7 5/8	203	1 1/2	38

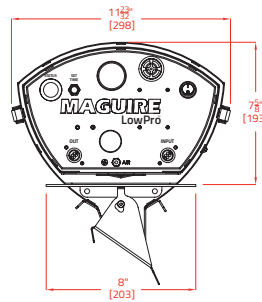

**Front View**  
(Same For All Models)

### LPR-A4

#### Side View

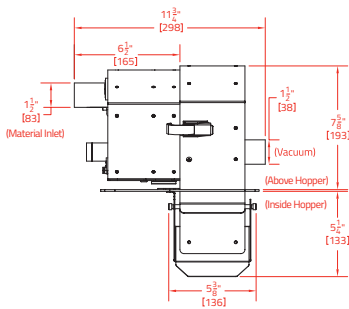

#### Lid Cutout

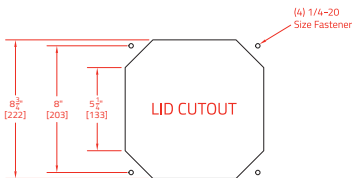

### LPR-A7

#### Side View

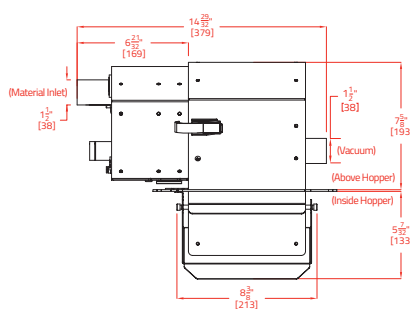

#### Lid Cutout

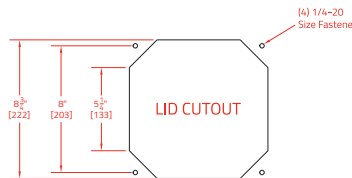

### LPR-A12

#### Side View

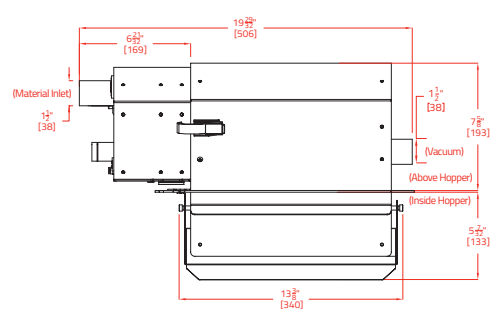

#### Lid Cutout

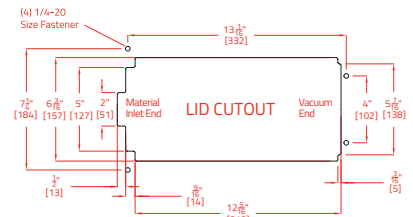

## LowPro Vacuum Mini Central Power Unit

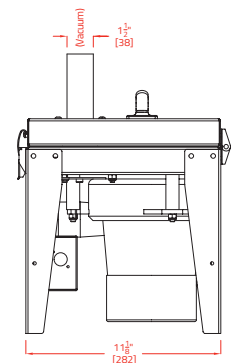
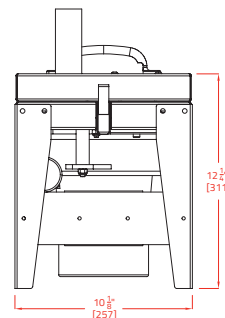
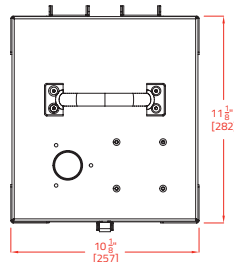

Power	Voltage	Height		Width		Depth		Standard Inlet Diameter	
		in	mm	in	mm	in	mm	in	mm
970W	220VAC/1ph/50Hz	12 1/4	311	10 1/8	257	11 1/8	282	1 1/2	38
	110VAC/1ph/60Hz								

Maguire reserves the right to cancel product or change product, product specifications and data without notice to improve reliability, function, design or otherwise.

[@MaguireProducts](#) | [in Maguire-Products](#) | [MaguireProducts](#) | [info@maguire.com](mailto:info@maguire.com) | [www.maguire.com](http://www.maguire.com)

USA Toll Free: +1 888 459 2412 | CANADA: +1 905 879 1100 | EUROPE: +44 1827 338 280 | ASIA: +65 68487117 | IMEA: +971 4 881 6700 | TAIWAN: +886 4 2658 1535